

# 3" T-ARMOR

**CONDENSED  
TECHNICAL  
REFERENCE**



Flat



Pencil Rib

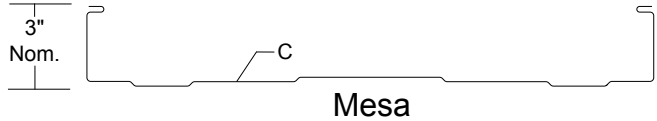

Mesa

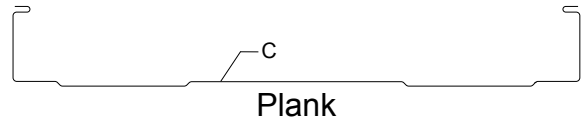

Plank

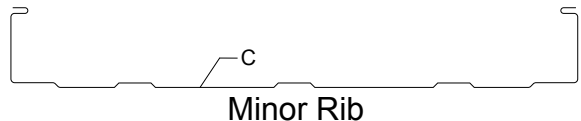

Minor Rib

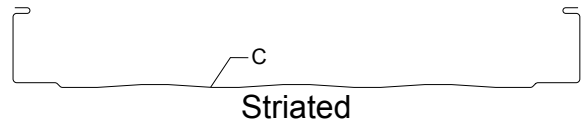

Striated

\*Profiles are shown for 16" wide panels. Other width panels are similar.

**ARCHITECTURAL  
COMMERCIAL  
INDUSTRIAL  
PANEL**

**CONCEALED  
FASTENED**

**12", 16" OR 18"  
COVERAGE**

**MINIMUM  
SLOPE  
1/2:12**

**OPEN FRAMING OR  
SOLID SUBSTRATE**

## PANEL OVERVIEW

- ▶ Finishes: PVDF and Acrylic Coated Galvalume®
- ▶ Corrosion Protection: AZ55 per ASTM A 792 for unpainted Galvalume®  
AZ50 per ASTM A 792 for painted Galvalume®  
G90 per ASTM A 653 for Galvanized
- ▶ Thickness: 24 ga, 22 ga and 20 ga
- ▶ 12", 16" or 18" panel coverage, 3" rib height
- ▶ Panel Length: Minimum: 6', Maximum: 80'
- ▶ Architectural, structural vertical rib standing seam roof system
- ▶ Integral mechanically seamed side lap with factory-applied sealant
- ▶ Minimum roof slope: 1/2:12
- ▶ Panels can be factory-notched
- ▶ Accommodates 1/2" to 6" blanket insulation

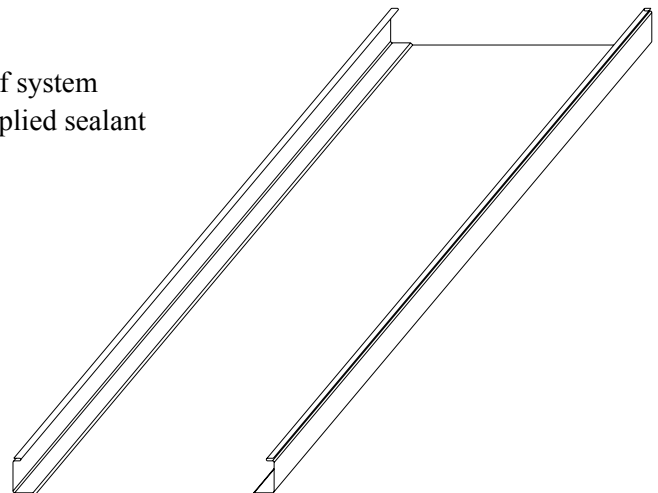

## TESTING AND APPROVALS

- ▶ UL 2218 Impact Resistance - Class 4
- ▶ UL 790 Fire Resistance Rating - Class A, per building code
- ▶ UL 263 Fire Resistance Rating - per assembly
- ▶ ASTM E 1592 Structural Performance
- ▶ \*ICC Evaluation Report

\* pending

**ms metal sales**  
manufacturing corporation

# 3" T-ARMOR

## CONDENSED TECHNICAL REFERENCE

### ATTACHMENT DETAILS

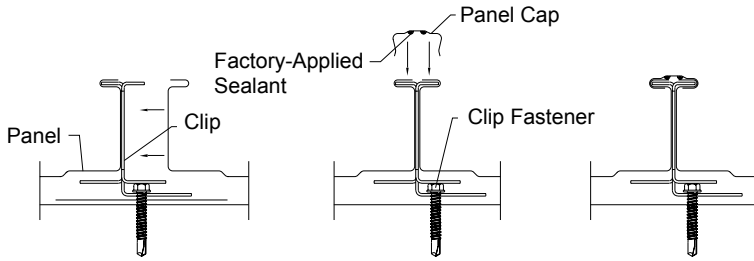

INSTALLING PANEL

INSTALLING CAP

SEAMED

### CLIP OPTIONS

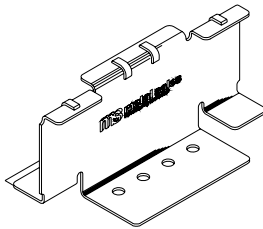

INDIVIDUAL CLIP

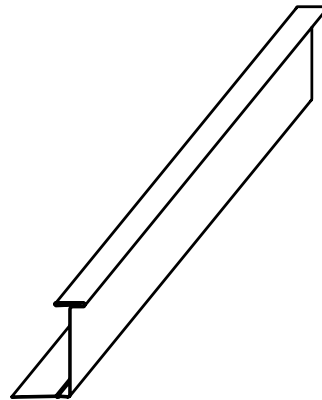

CONTINUOUS CLIP

### FASTENING INFORMATION

#### ► Clips

Clip spacing is based upon the design loads, the spanning capacity of the panels, the fasteners and the support members.

Individual clips are 0.060" thick, G90 is standard, 410 stainless is optional. Continuous clips are 24 or 22 ga.

Both Individual and continuous clips can accommodate practically unlimited thermal movement in each direction.

#### ► Fasteners

Overdriven fasteners will cause panel distortions.

Fasteners should extend 1/2" or more past the inside face of the support material.

#### Clip Fasteners:

Attaching to Wood:

#12-11 x 1-1/2" Wood Screw

Attaching to Steel:

<18 ga: 1/4"-14 Deck Screw

>=18 ga, <=12 ga: 1/4"-14 Driller, No Washer

>12 ga: 1/4"-24 Driller, No Washer

#### Exposed End Fasteners:

At Eave Plate or Back-Up Channel:

#12-14 XL Driller

#### Concealed End Fasteners:

At Eave Plate or Back-Up Channel:

#12-14 Driller, No Washer

#### Trim Fasteners:

1/4"-14 x 7/8" XL Stitch Screw

1/8" x 3/16" Pop Rivet

### STEEL SECTION PROPERTIES

Ga.	Width in	Yield ksi	Weight psf	Top In Compression		Bottom In Compression		Inward Load						Outward Load					
				Ixx in <sup>4</sup> /ft	Sxx in <sup>3</sup> /ft	Ixx in <sup>4</sup> /ft	Sxx in <sup>3</sup> /ft	2'	2.5'	3'	3.5'	4'	5'	2'	2.5'	3'	3.5'	4'	5'
24	12	50	1.60	0.5756	0.2723	0.3676	0.2442	400	400	379	306	251	178	51	47	44	41	37	31
22	12	50	2.10	0.7900	0.3776	0.5290	0.3434	400	400	400	400	400	284	51	47	44	41	37	31
20	12	33	2.57	0.9970	0.4828	0.7140	0.4332	400	400	400	400	377	250	51	47	44	41	37	31
24	16	50	1.43	0.4665	0.2063	0.2235	0.1328	400	323	247	195	157	107	51	47	44	41	37	31
22	16	50	1.87	0.6428	0.2869	0.3195	0.1964	400	400	400	325	256	170	51	47	44	41	37	31
20	16	33	2.29	0.8213	0.3716	0.4320	0.2786	400	400	400	318	249	163	51	47	44	41	37	31
24	18	50	1.37	0.4260	0.1839	0.1987	0.1177	390	287	219	173	139	95	51	47	44	41	37	31
22	18	50	1.80	0.5887	0.2560	0.2840	0.1743	400	400	376	289	228	151	51	47	44	41	37	31
20	18	33	2.20	0.7547	0.3333	0.3833	0.2475	400	400	372	282	221	145	51	47	44	41	37	31

- Theoretical section properties have been calculated per AISI 2007 'North American Specification for the Design of Cold-Formed Steel Structural Members'. Ixx and Sxx are effective section properties for deflection and bending.
- Allowable loads are calculated in accordance with AISI 2007 specifications considering bending, shear, combined bending and shear, deflection and ASTM E 1592 uplift load testing on 16 ga purlins. Allowable loads consider the 3 or more equal spans condition. Panel weight is not considered.
- Deflection consideration is limited by a maximum deflection ratio of L/180 of span.
- Allowable loads do not include a 1/3 stress increase for wind.

**metal sales**  
manufacturing corporation



Anchorage, AK 866.640.7663  
Bay City, MI 888.777.7640  
Deer Lake, PA 800.544.2577  
Denver, CO 800.289.7663  
Detroit Lakes, MN 888.594.1394  
Fontana, CA 800.782.7953  
Fort Smith, AR 877.452.3915

Independence, MO 800.747.0012  
Jacksonville, FL 800.394.4419  
Jefferson, OH 800.321.5833  
Mocksville, NC 800.228.6119  
Nashville, TN 800.251.8508  
Rock Island, IL 800.747.1206  
Rogers, MN 800.328.9316

Seattle, WA 800.431.3470  
Sellersburg, IN 800.999.7777  
Sioux Falls, SD 888.902.8320  
Spokane, WA 800.572.6565  
Temple, TX 800.543.4415  
Woodland, CA 800.759.6019  
**metalsales.us.com**